

100th
VESSEL 1916-2016

●Product specifications, dimensions, pricing, and other information are subject to change without notice.

Manufactured by:

VESSEL Co., Inc.

17-25, Fukae-Kita 2-chome, Higashinari-ku, Osaka 537-0001 JAPAN
Tel: + 81 (0) 6 6976 7778 Fax : + 81 (0) 6 6972 9441
export@vessel.co.jp www.vessel.co.jp/english/

VESSEL EUROPE

6, avenue du 1er Mai, ZAE Les Glaises, 91120 Palaiseau FRANCE
Tel: + 33 (0) 1 69 19 17 42 Fax : + 33 (0) 1 69 19 42 20
contact@vessel-europe.com www.vessel-europe.com

INDUSTRIAL BITS CATALOGUE



<https://www.vessel-europe.com/>
<http://www.vessel.co.jp/english/bitsocket/>

VESSEL

Challenging for best performing the dedication to high precision

For **VESSEL**, quality means to meet bit users' applications.
The quality bit production is supported by the latest precise cutting machines,
heat-treatment equipment, with the latest microscope for the precision cutting control.

industrial bits, electronic device screw fastening

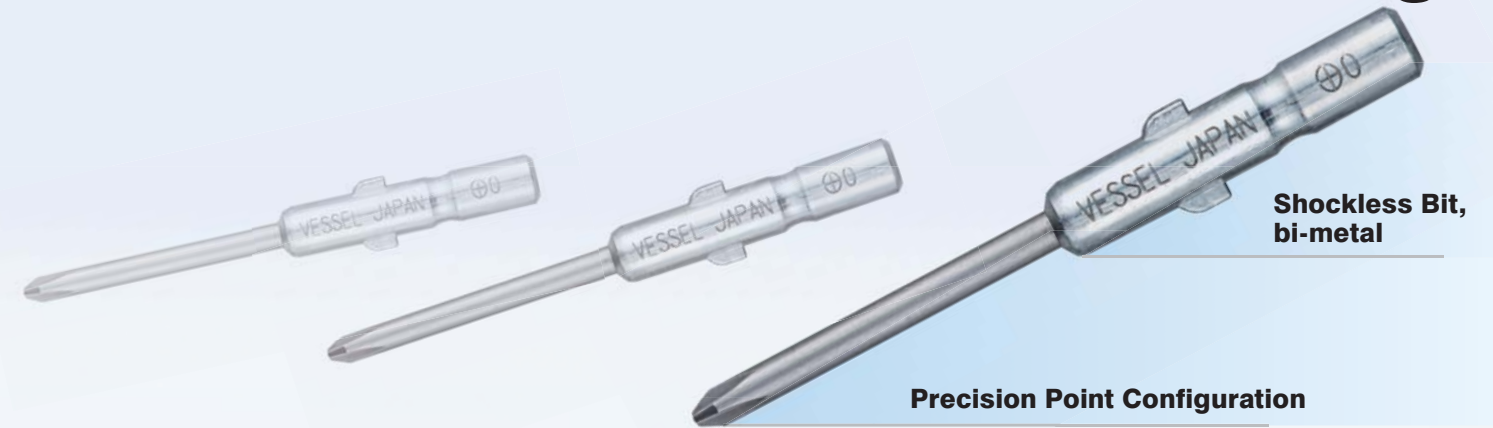

Quality Control Specs.

More precision and superior quality to meet the latest electronic applications.
Updated production facilities and inspection equipment to meet today's high quality applications required in the market.

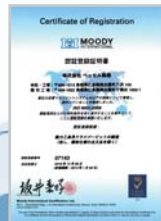
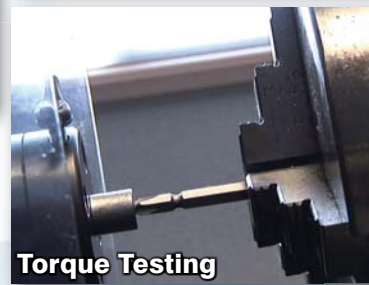
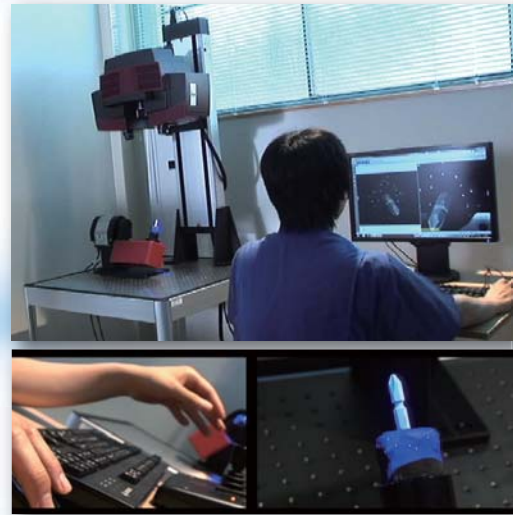

About ISO

ISO 9001

All manufacturing divisions have begun the process of earning certification under the ISO 9000 series of quality management system standards.



ISO 14001

We obtained ISO 14001 in August 2010. VESSEL will further strive to offer eco-friendly products, aiming at minimizing the environmental burden as a manufacturing group.

Latest Technology Support

Consistent production system, from steel material selection, to machining, pressing, heat-treatment, surface finish, and final inspection before shipment



Plasma/vacuum furnaces add wider applications



24-hour unmanned operation with manufacturing systems for cutting-edge technology

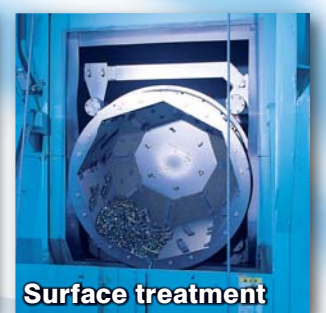

GENERAL INFORMATION

SELECTION OF THE PROPER HEAT TREATMENT

The selection of the proper heat treatment is important in securing the longest life for bits, but it may require some trial and error to select the proper heat treatment for a particular application.

If your bits tend to get broken or chip-off, switch to a bit with less hardness. If your bits wore quickly, choose a harder bit. However, bits may often break or get worn due to various factors such as different operators, different torque values and different power tool settings.

VESSEL industrial bits are classified according to three main heat treatment classes; "X", "H" and "G".

APPLICATIONS HEAT TREATMENT CLASS	SCREWS TO BE FASTENED	TYPE OF WORK	TYPE OF FIELD
X HIGHEST HARDNESS HRC 62±1	HIGH-HARDNESS SCREWS SUCH AS TAP SCREWS, SELF-DRILLING TAP SCREWS	LIGHT & LOW TORQUE WORK BY TORQUE CONTROL AIR S/DRIVER, ELECTRIC S/DRIVER, AUTOMATIC SCREW FASTENING DEVICE, FOR EXAMPLE	AUTOMATIC ASSEMBLY OF PRECISE EQUIPMENT & AUDIO EQUIPMENT
H HIGH HARDNESS HRC 60±1	MEDIUM-HARD SCREWS SUCH AS TAP SCREWS	MEDIUM & LOW TORQUE WORK BY SPEED-REDUCING AIR S/DRIVERS & ELECTRIC S/DRIVER, FOR EXAMPLE	ASSEMBLY & DISASSEMBLY OF HOME ELECTRIC APPLIANCES & ASSEMBLY OF COMMUNICATION EQUIPMENT & AUDIO EQUIPMENT
G STANDARD HARDNESS HRC 57±1	STANDARD HARDNESS SCREWS SUCH AS SMALLMACHINE SCREWS & WOOD SCREWS	HEAVY DUTY WORK INCLUDING HIGH TORQUE & HIGH IMPACT APPLICATIONS, ESPECIALLY USEFUL WITH IMPACT TYPE AIR S/DRIVER	AUDIO PARTS, MACHINE PARTS, WOODEN MOULDINGS SUCH AS WINDOW DOOR SASHES & FURNITURE

In general, high torque applications require "G" hardness to withstand twisting and resist breakage.

The "H" hardness is for medium torque applications, and this class is most common and should be selected for normal application.

The "X" hardness is most suitable for low torque applications, particularly if hardened screws are used.

In addition to above three classes, low hardness "E" HRC 55±1 and lowest hardness "S" HRC 53±1 are also available for use in heavy duty work where high impact is anticipated.

Dimensions and specifications are subject to be changed without notice in advance.

FOR SAFTY USE

Read the instruction manual and observe the safety precautions and warnings.

<http://www.vessel.co.jp/english/info/safety-bit.html>



- Do not use any bits if cracked, chipped, worn, deformed or otherwise not in perfect working order.
- Do not use on live current. Use bits and sockets of the required size for the target screws, bolts and nuts.
- Never drive power tools idly with bits or sockets attached.
- Shut off power before mounting or replacing bits.
- Wear protective goggles when working.

GENERAL INFORMATION

HOW TO ENQUIRE AND ORDER SPECIAL ITEM

If you do not find any bits or sockets suitable for your work in our product line up, we also offer made-to-order products tailored to your specifications.



Bits for automated assembly lines

High-precision processing is required for bits to be installed in automatic assembly machines, which operate in micro-level accuracy. VESSEL has technology and know-how for such precision bits as one of the biggest bit manufacturers in the world.



Innovative material and surface treatment

We choose most suitable materials and surface treatment methods for each different application, for example, high-endurance bits made of corrosion-resistant stainless steel and high-speed steel, etc.



Laser marking

Necessary information can be directly laser-marked on bits, which brings further efficiency to your inventory management.



Order-made bit database

All the previous orders are recorded and organized by computer system.

Points to be checked when arranging made-to-order bits and sockets production

General Purpose of the bits?

- General Information about the application
- General Information about the environment (industry line, cleanroom, ...)

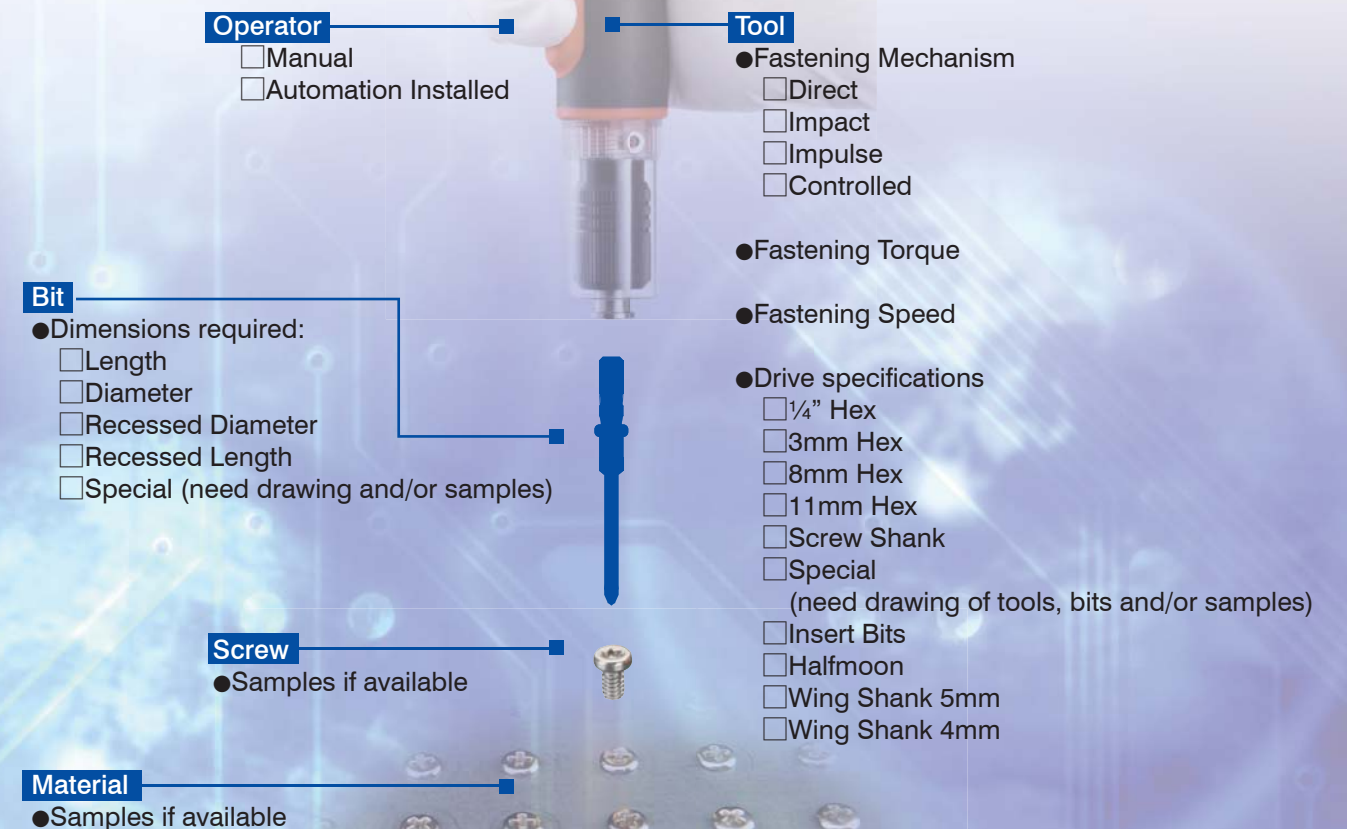

CONTENTS

P 7	• BITS FOR PRECISION SCREW Wing-shank Halfmoon	
P 12	• BITS FOR PRECISION SCREW 3mm Hex Drive	
P 13	• INSERT BITS 6.35mm Hex shank 8mm Hex shank	
P 16	• POWER BITS 6.35mm Hex Drive	
P 22	• MAGNUM BITS/CUSHION BITS NEW 6.35mm Hex Drive	
P 24	• DOUBLE END POWER BITS 6.35mm Hex Drive • BIT MAG-BOTTLE NEW • MAGNET VISCATCHER	
P 26	• PH/PZ-PLAIN SLOTTED BITS 6.35mm Hex Drive	
P 27	• SOCKET BITS, NUT SETTERS 6.35mm Hex Drive	
P 29	• POWER BITS 8mm Hex Drive 11mm Hex Drive	
P 30	• ADAPTERS 6.35mm Hex Drive • SCREW SHANK DRIVE BITS • BIT HOLDERS 6.35mm Hex Drive	
P 31	• BIT HOLDERS WITH MG.VISCATCH • TORSION BIT HOLDER • MG.VISCATCH BIT 6.35mm Hex Drive	
P 34	INQUIRY SHEET	

NEW Products for Precision Fastening **Shockless Bit**

*Posed with the challenge
“Can fastening precision be improved
with the bit itself?”*

VESSEL sought out a single answer.

We found the hint in torsion bits.

By providing the bit with a torsion zone, the impact applied in the instant that the screw is seated is absorbed, and chipping of the tool tip is suppressed.

We were also able to greatly reduce the rush acceleration at the time of seating by reducing the bit's weight.

A more stable torque accuracy can be attained with the “Impact & Moment of Inertia Absorption” effect applied on the bit. **VESSEL Shockless Bit**.



●Stable tightening torque

The combination of alloy steel and zinc creates a shockless effect and stabilizes the tightening torque.

[Measurement of tightening waveform]

The load during screw tightening is indicated as a waveform

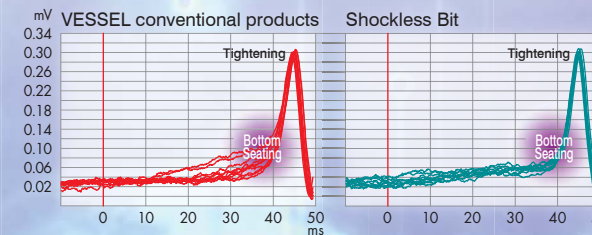

●Break-resistant with improved durability

The shockless effect of the alloy steel and zinc combination greatly improves the durability of the tool tip.

[Driving durability test]

Number of tools which do not break when continuously screwed in by a screw tightening robot.



Cushion effect of combination of several materials enables the impact on the tip-end to be absorbed and makes the bit durable. This also leads to less damage on screw or workpieces as Shockless Bit is not merely hard but cushiony.

Structure

Zinc die cast

Acts as cushioning to absorb the impact when the screw is seated.

Combination of different materials

This is Vessel's original technology that brings out the bit's performance to the fullest. Our “eco-friendly bit” reduces the discharge of cutting chips during manufacturing.

ECO Eco-friendly product

Special alloy steel Precision cutting and hardening

Vessel's original blend of steel exclusively for bits is processed and hardened to achieve a high hardness and wear resistance. Core deviation accuracy: Standard within 0.2 mm (40 mm product)





BITS FOR PRECISION SCREW

EDP No.	Model No.	PH	ϕd	l	L
446001	D73 +00x1.2x40	00	1.2	20	40
483001	D73 +00x1.5x40	00	1.5	20	40
483002	D73 +00x1.5x60	00	1.5	20	60
483005	D73 +00x2x40	00	2	20	40
483006	D73 +00x2x60	00	2	20	60
446016	D73 +0x1.4x40	0	1.4	20	40
446017	D73 +0x1.4x60	0	1.4	20	60
483010	D73 +0x1.7x40	0	1.7	20	40
483011	D73 +0x1.7x60	0	1.7	20	60
446025	D73 +0x2x40	0	2	20	40
446026	D73 +0x2x60	0	2	20	60
446027	D73 +0x2x80	0	2	20	80
446028	D73 +0x2x100	0	2	20	100
483015	D73 +0x2.5x40	0	2.5	20	40
483016	D73 +0x2.5x60	0	2.5	20	60
446033	D73 +0x2.5x80	0	2.5	20	80
446034	D73 +0x2.5x100	0	2.5	20	100
483021	D73 +1x3x40	1	3	20	40
446053	D73 +1x3x60	1	3	20	60
446054	D73 +1x3x80	1	3	20	80
446055	D73 +1x3x100	1	3	20	100
483376	D73 +1x3x120	1	3	20	120
483025	D73 +1x4x40	1	4	-	40
446059	D73 +1x4x60	1	4	-	60
483031	D73 +2x4x40	2	4	-	40
446070	D73 +2x4x60	2	4	-	60
446071	D73 +2x4x80	2	4	-	80
446072	D73 +2x4x100	2	4	-	100
446073	D73 +2x4x120	2	4	-	120

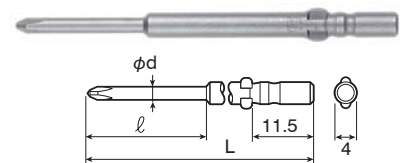

EDP No.	Model No.	PZ	ϕd	L
447414	D73 PZ0x60	0	4	60
447415	D73 PZ1x60	1	4	60
447430	D73 PZ2x60	2	4	60

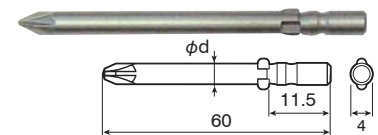

EDP No.	Model No.	w	t	l	L
483041	D73 -2x0.3x40	2	0.3	20	40
483042	D73 -2.5x0.3x40	2.5	0.3	20	40
483043	D73 -3x0.4x40	3	0.4	20	40
483044	D73 -4x0.5x40	4	0.5	-	40

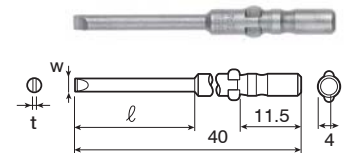

EDP No.	Model No.	H	ϕd	l	L
483051	D73 H1.5x60	H1.5	2	20	60
483052	D73 H2x60	H2	3	20	60
483053	D73 H2.5x60	H2.5	3	20	60
483054	D73 H3x60	H3	4	-	60

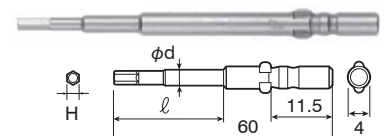



BITS FOR PRECISION SCREW

EDP No.	Model No.	T	ϕ d	<i>l</i>	L
635621	D73 T1x40	T1	1.5	20	40
635622	D73 T2x40	T2	1.5	20	40
635623	D73 T3x40	T3	1.7	20	40
635624	D73 T4x40	T4	1.8	20	40
446107	D73 T5x40	T5	2	20	40
446108	D73 T5x60	T5	2	20	60
446109	D73 T6x40	T6	2.5	20	40
446110	D73 T6x60	T6	2	20	60
446113	D73 T7x60	T7	2	20	60
635628	D73 T8x40	T8	2.5	20	40
446116	D73 T8Hx60	T8H	4	-	60
635629	D73 T9x40	T9	3	20	40
635630	D73 T10x40	T10	3	20	40
446119	D73 T10Hx60	T10H	4	-	60

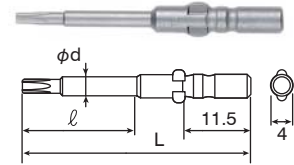

EDP No.	Model No.	IP	ϕ d	<i>l</i>	L
447416	D73 4IPx60	4IP	1.8	20	60
447417	D73 5IPx60	5IP	2	20	60
447418	D73 6IPx60	6IP	2.5	20	60
447419	D73 8IPx60	8IP	3	20	60
447420	D73 10IPx60	10IP	3	20	60

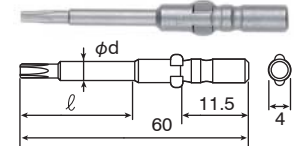

EDP No.	Model No.	PH	ϕ d	<i>l</i>	L
483801	DS73 +00x1.5x40	00	1.5	20	40
483802	DS73 +00x1.5x60	00	1.5	20	60
483809	DS73 +0x1.5x40	0	1.5	20	40
483810	DS73 +0x1.5x60	0	1.5	20	60
483811	DS73 +0x1.7x40	0	1.7	20	40
483812	DS73 +0x1.7x60	0	1.7	20	60
483813	DS73 +0x2x40	0	2	20	40
483814	DS73 +0x2x60	0	2	20	60



Shockless Bit

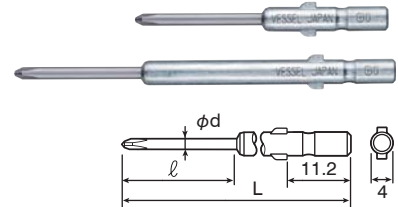

EDP No.	Model No.	T	ϕ d	<i>l</i>	L
483901	DS73 T5x2x40	T5	2	20	40
483902	DS73 T5x2x60	T5	2	20	60
483903	DS73 T6x2x40	T6	2	20	40
483904	DS73 T6x2x60	T6	2	20	60



Shockless Bit

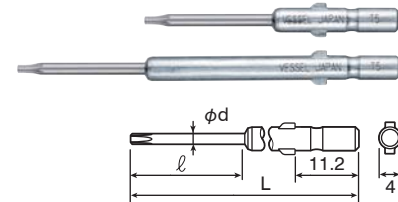

MEGADORA HANDLE

EDP No.	Model No.	Description
122483	910HD-73	MEGADORA Bit Holder, D73 ϕ 4mm Wing-shank

Package 10pcs

NEW

Precision bits can be installed.

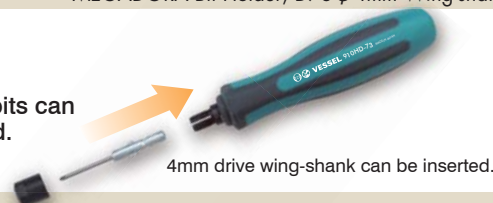

4mm drive wing-shank can be inserted.

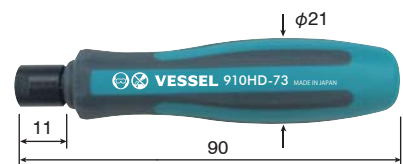

※ The specifications and others are subject to change without prior notice.
 ※ Designed for Max. 3.0N·m, applicable to the tip-end size upto PH1, PZ0, (-)4, H2.5, T9, and 8IP respectively.



BITS FOR PRECISION SCREW

EDP No.	Model No.	PH	ϕd	ℓ	L
483115	D76 +0x2.5x60	0	2.5	25	60
483121	D76 +1x3x60	1	3	30	60
446267	D76 +1x3x80	1	3	30	80
483125	D76 +1x5x60	1	5	-	60
483131	D76 +2x5x60	2	5	-	60
446281	D76 +2x5x120	2	5	-	120
446282	D76 +2x5x150	2	5	-	150

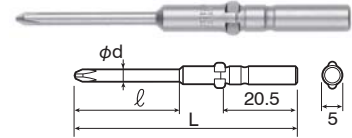

EDP No.	Model No.	w	t	ℓ	L
483141	D76 -3x60	3	0.4	30	60
483142	D76 -4x60	4	0.6	30	60
483143	D76 -5x60	5	0.7	-	60

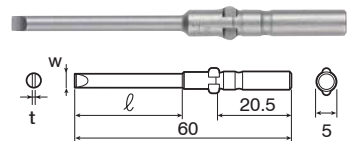

EDP No.	Model No.	H	ϕd	ℓ	L
483151	D76 H2x70	H2	3	30	70
483152	D76 H2.5x70	H2.5	3	30	70
483153	D76 H3x70	H3	4	30	70
483154	D76 H4x70	H4	5	-	70

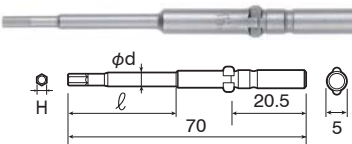

EDP No.	Model No.	T	ϕd	ℓ	L
635651	D76 T5x60	T5	2	20	60
635652	D76 T6x60	T6	2.5	20	60
635653	D76 T7x60	T7	2.5	20	60
635654	D76 T8x60	T8	3	20	60
635655	D76 T9x60	T9	3	20	60
635656	D76 T10x60	T10	3	20	60
635657	D76 T15x60	T15	4	20	60
635658	D76 T20x60	T20	-	-	60
635659	D76 T25x60	T25	-	-	60



TORX®

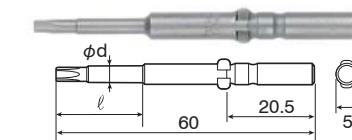



BITS FOR PRECISION SCREW

EPD No.	Model No.	PH	ϕd	l	L
482901	D71 +00×1.5×44	00	1.5	20	44
482902	D71 +00×1.5×64	00	1.5	20	64
446293	EPH204	00	2	20	64
446290	EPH201	0	1.8	20	44
446291	EPH202	0	1.8	20	64
482911	D71 +0×2×44	0	2.0	20	44
482912	D71 +0×2×64	0	2.0	20	64
446294	EPH205	0	2.5	20	44
446295	EPH206	0	2.5	20	64
482921	D71 +1×3×44	1	3	20	44
482922	D71 +1×3×64	1	3	20	64
446298	EPH209	1	4	—	44
446299	EPH210	1	4	—	64
446300	EPH211	2	4	—	44
446301	EPH212	2	4	—	64

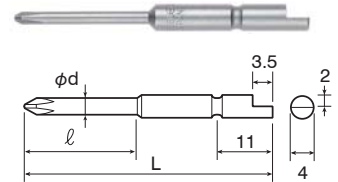

EDP No.	Model No.	PZ	ϕd	l	L
447422	D71 PZ0×44	0	2.5	20	44
447423	D71 PZ0×64	0	2.5	20	64
447424	D71 PZ1×44	1	4	—	44
447425	D71 PZ1×64	1	4	—	64

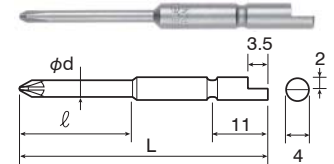

EDP No.	Model No.	w	t	l	L
446303	EPL221	2	0.3	20	44
446304	EPL222	2.5	0.3	20	44
446305	EPL223	3	0.4	20	44
446306	EPL224	4	0.5	—	44

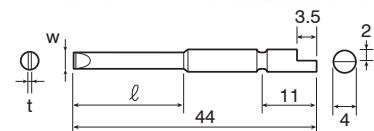

EDP No.	Model No.	H	ϕd	l	L
446308	EHW231	H1.5	3	20	44
446309	EHW232	H2	3	20	44
446310	EHW233	H2.5	3.5	20	44
446311	EHW234	H3	4	—	44

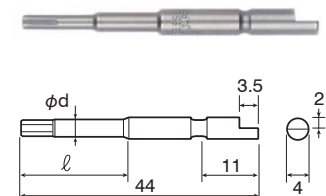

EDP No.	Model No.	A/F	ϕD	l	l_2	L
446312	EBX241	A/F2.3	4	5	—	44
446313	EBX242	A/F2.5	4	5	—	44
446314	EBX243	A/F3	5	8	20	44
446315	EBX244	A/F4	7	10	20	44
446316	EBX245	A/F4.5	7	10	20	44
446317	EBX246	A/F5	8	15	20	44
446318	EBX247	A/F5.5	8	15	20	44

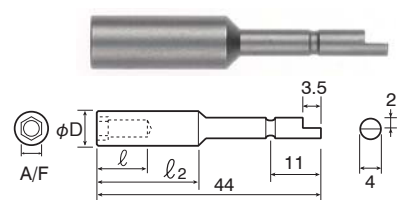

Drive: ϕ 4mm DRIVE Halfmoon 

For: DELVO

BITS FOR PRECISION SCREW

EDP No.	Model No.	T	ϕ d	ℓ	L
635601	D71 T1×44	T1	1.5	20	44
635602	D71 T2×44	T2	1.5	20	44
635603	D71 T3×44	T3	1.7	20	44
635604	D71 T4×44	T4	1.8	20	44
446319	ETX250	T5	2	6.5	44
446320	ETX251	T5	2	6.5	64
446321	ETX252	T6	2	6.5	44
446322	ETX253	T6	2	6.5	64
635607	D71 T7×44	T7	2.5	20	44
635608	D71 T8×44	T8	3	20	44
446323	ETX254	T8H	3	20	44
446324	ETX255	T8H	3	48	64
635609	D71 T9×44	T9	3	20	44
446325	ETX256	T10H	3	7.5	44
446326	ETX257	T10H	3	7.5	64
446328	ETX259	T15H	4	7.5	64

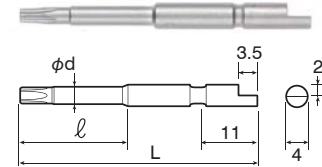

EDP No.	Model No.	IP	ϕ d	ℓ	L
447428	D71 2IP×44	2IP	1.5	20	44
447412	D71 2IP×64	2IP	1.5	20	64
447429	D71 3IP×44	3IP	1.7	20	44
447413	D71 3IP×64	3IP	1.7	20	64
447402	D71 4IP×44	4IP	1.8	20	44
447403	D71 4IP×64	4IP	1.8	20	64
447404	D71 5IP×44	5IP	2	20	44
447405	D71 5IP×64	5IP	2	20	64
447406	D71 6IP×44	6IP	2.5	20	44
447407	D71 6IP×64	6IP	2.5	20	64
447408	D71 8IP×44	8IP	3	20	44
447409	D71 8IP×64	8IP	3	20	64
447410	D71 10IP×44	10IP	3	20	44
447411	D71 10IP×64	10IP	3	20	64

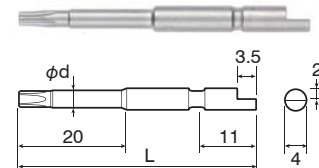

Drive: 1/4" = 6.35mm HEX DRIVE  DIN3126-E6.3

For:

AEG, ARO, ATLAS-COPCO, BIAH, B&D, BOSCH, BUCKEYE-TOOLS, CHICAGO-PNEUMATIC, CLECO, DEPRAG, DESOUTTER, GARDNER-DENVER, HIOS (FERRA TOOLS), HITACHI, INGERSOLL, IWEMA, KELLER, MAKITA, MALL, METABO, NPK, PNEUTEC, ROCKWELL, ROTOR-TOOL, SKIL, STANLEY, THOR, TOHNICHI, URYU, VAN-DORN, VIRAX, WOLF, YOKOTA, YUTANI

BIT HOLDER (For 4mm drive halfmoon)

EDP No.	Model No.	L
482430	HD71×41.5	41.5

Precision bits can be installed to electric screwdrivers.

4mm drive halfmoon bits
(→ See P8 also)
can be inserted.



Precision Bit 4mm drive halfmoon

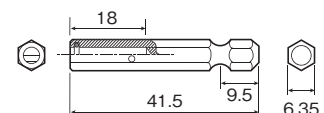

* Production upon your order

**Drive: 3mm HEX DRIVE
DIN3126-A5.5**

For: BIAX, BOSCH, DEPRAG, DESOUTTER



BITS FOR PRECISION SCREW

EDP No.	Model No.	PH	ϕD	l	L
446645	D79 +00x2.5x50	00	2.5	24	50
446646	D79 +0x2.5x50	0	2.5	24	50
446647	D79 +1x4x50	1	4	30.5	50

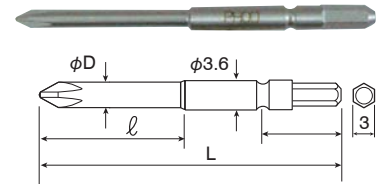

EDP No.	Model No.	PZ	ϕD	l	L
446657	D79 PZ0x50	0	3.0	24	50
446658	D79 PZ1x50	1	4.0	30.5	50

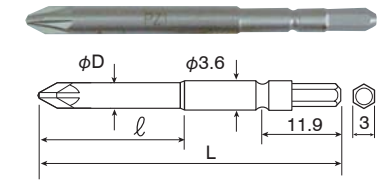

EDP No.	Model No.	w	t	l	L
446648	D79 -1.8x0.3x50	1.8	0.3	24	50
446649	D79 -2x0.4x50	2	0.4	24	50
446650	D79 -2.5x0.4x50	2.5	0.4	24	50
446651	D79 -3x0.5x50	3	0.5	24	50
446653	D79 -3.5x0.6x50	3.5	0.6	24	50
446652	D79 -4x0.5x50	4	0.5	30.5	50
446655	D79 -4x0.8x50	4	0.8	30.5	50
446654	D79 -4.5x0.6x50	4.5	0.6	30.5	50
446656	D79 -5.5x0.8x50	5.5	0.8	30.5	50

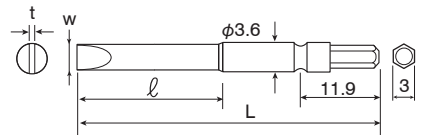

EDP No.	Model No.	T	A	ϕd	L
446659	D79 T6x2.2x50	T6	1.65	2.2	50
446660	D79 T7x2.2x50	T7	1.99	2.2	50
446661	D79 T8x2.8x50	T8	2.31	2.8	50
446662	D79 T10x3x50	T10	2.74	3.0	50



TORX®

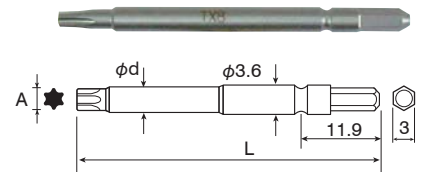

* Production upon your order

**Drive: 1/4" = 6.35mm HEX SHANK
DIN3126-C6.3**



For: 1/4" HEX OPENING BIT HOLDERS

INSERT BITS

EDP No.	Model No.	PH	ϕd	ℓ	L
489001	3000/25	0	3	12	25
489002	3001R/25	1	4.5	12	25
489003	3002R/25	2	5	12	25
489018	3002R/50	2	6	38	50

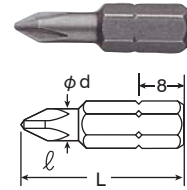

EDP No.	Model No.	PH	ϕd	L
487100	1010	0	4.5	25.4
487105	1001	1	—	25.4
487106	1002	2	—	25.4
487107	1003	3	—	25.4

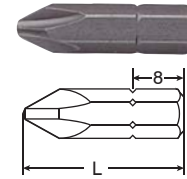

EDP No.	Model No.	PZ	ϕd	ℓ	L
447344	3000/25PZ	0	3	12	25
489014	3001/25PZC	1	4.5		25
489015	3002/25PZC	2	6		25.4
489016	3003/25PZC	3	6		25.4

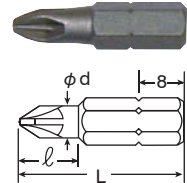

EDP No.	Model No.	PZ	L
487115	1001PZ	1	25.4
489022	3001/50PZ	1	50
487116	1002PZ	2	25.4
489023	3002/50PZ	2	50
487117	1003PZ	3	25.4
489024	3003/50PZ	3	50

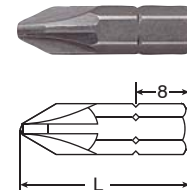

EDP No.	Model No.	w	t	L
489678	5635/25	3.5	0.55	25
489062	5604/25	4	0.6	25
489064	5605/25	5	0.75	25
446389	5655/25	5.5	0.8	25

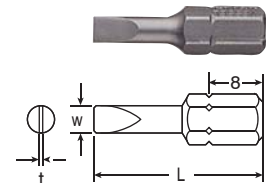

EDP No.	Model No.	w	t	L
487120	1501	4.76	0.86	25.4
487121	1502	5.55	1.02	25.4
487122	1503	6.35	1.07	25.4
487123	1504	7.14	1.17	25.4
487124	1505	8	1.27	25.4

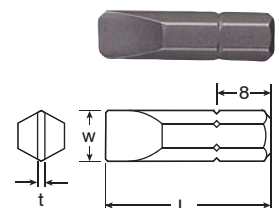

*Production upon your order

**Drive: 1/4" = 6.35mm HEX SHANK
DIN3126-C6.3**



For: 1/4" HEX OPENING BIT HOLDERS

INSERT BITS

EDP No.	Model No.	H	ϕd	L
489050	30315/25	H1.5	1.75	25
489051	3032/25	H2	2.35	25
489052	30325/25	H2.5	3	25
489053	3033/25	H3	3.55	25
489054	3034/25	H4	4.75	25
487142	21004	H4		33.3
489055	3035/25	H5	5.85	25
487143	21005	H5		33.3
489056	3036/25	H6	—	25
487144	21006	H6		33.3
489057	3038/25	H8	—	25
487145	21008	H8		31.8

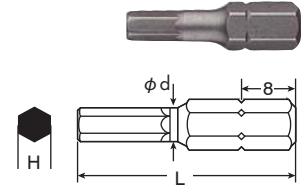

EDP No.	Model No.	T	A	ϕd	L
489154	T03/25	T3	1.12	1.14	25
489155	T05/25	T5	1.37	1.67	25
489156	T06/25	T6	1.65	1.95	25
489157	T07/25	T7	1.99	2.27	25
489158	T08/25	T8	2.31	2.60	25
489159	T09/25	T9	2.5	2.78	25
489160	T10/25	T10	2.74	3.02	25
489161	T15/25	T15	3.27	3.56	25
489162	T20/25	T20	3.86	4.14	25
489163	T25/25	T25	4.43	4.70	25
489164	T27/25	T27	4.99	5.26	25
489165	T30/25	T30	5.52	5.79	25
489166	T40/25	T40	6.3	—	25

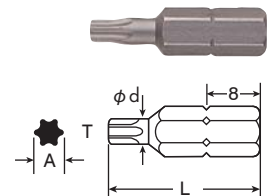

EDP No.	Model No.	T	A	ϕd	L
446392	TF08/25	T8H	2.31	2.60	25
446393	TF09/25	T9H	2.5	2.78	25
489167	TF10/25	T10H	2.74	3.02	25
489168	TF15/25	T15H	3.27	3.56	25
489169	TF20/25	T20H	3.86	4.14	25
489170	TF25/25	T25H	4.43	4.70	25
489171	TF27/25	T27H	4.99	5.26	25
489172	TF30/25	T30H	5.52	5.79	25

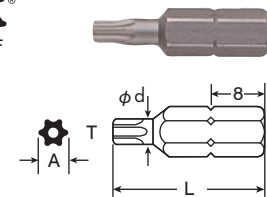

**Drive: 5/16" = 8mm HEX SHANK
DIN3126-C8**



For: 5/16" HEX OPENING BIT HOLDERS

EDP No.	Model No.	H	ϕd	ℓ	L
489103	3045/34	H5	5	13	34
489104	3046/34	H6	6	13	34
447308	3047/34	H7			34
489105	3048/34	H8			34
489106	3050/34	H10	12	16	34

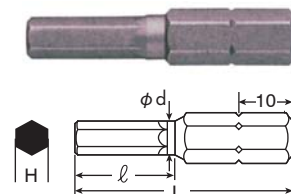

* Production upon your order

**Drive: 1/4" = 6.35mm HEX SHANK
DIN3126-C6.3**



For: 1/4" HEX OPENING BIT HOLDERS

INSERT BITS

EDP No.	Model No.	IP	A	ϕd	L
447201	6IP/25	6IP	1.64	1.95	25
447202	8IP/25	8IP	2.31	2.60	25
447203	10IP/25	10IP	2.72	3.02	25
447204	15IP/25	15IP	3.25	3.56	25
447205	20IP/25	20IP	3.84	4.14	25
447206	25IP/25	25IP	4.39	4.70	25
447207	30IP/25	30IP	5.49	5.79	25
447208	40IP/25	40IP	6.3	—	25

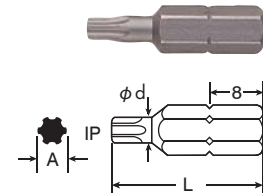

EDP No.	Model No.	SQ	L
487150	3001	1 (3/32")	25.4
487151	3002	2 (1/8")	25.4
487152	3003	3 (9/64")	25.4

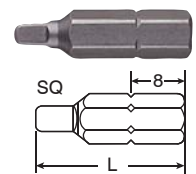

EDP No.	Model No.	H	L
446402	3720/25	H2	25
446403	3725/25	H2.5	25
446404	3730/25	H3	25
446405	3740/25	H4	25
446406	3750/25	H5	25
446407	3760/25	H6	25
446408	3780/25	H8	25

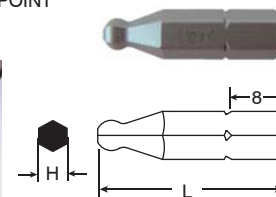

EDP No.	Model No.	TW	L
446411	4001	TW1	25.4
446412	4002	TW2	25.4
446413	4003	TW3	25.4
446414	4004	TW4	25.4

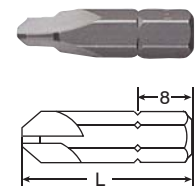

* Production upon your order

**Drive: 1/4" = 6.35mm HEX DRIVE
DIN3126-E6.3**



For:

AEG, ARO, ATLAS-COPCO, BIAx, B&D, BOSCH, BUCKEY-TOOLS, CHICAGO-PNEUMATIC, CLECO, DEPRAG, DESOUTTER, GARDNER-DENVER, HIOS (FERRA TOOLS), HITACHI, INGERSOLL, IWEMA, KELLER, MAKITA, MALL, METABO, NPK, PNEUTEC, ROCKWELL, ROTOR-TOOL.SKIL, STANLEY, THOR, TOHNICHI, URYU, VAN-DORN, VIRAX, WOLF, YOKOTA, YUTANI

POWER BITS

EDP No.	Model No.	PH	φD	ℓ	L
446126	B35 +00x1.2x60	00	1.2	20	60
446423	10600	00	1.58	-	49
447347	10700	00	1.58	-	70
446128	B35 +00x1.5x60	00	1.5	20	60
446130	B35 +00x1.7x60	00	1.7	20	60
446139	B35 +00x2x40x60	00	2	40	60
446141	B35 +00x2x100	00	2	40	100
446145	B35 +0x1.4x60	0	1.4	30	60
446150	B35 +0x1.7x60	0	1.7	30	60
446151	B35 +0x1.7x80	0	1.7	40	80
446153	B35 +0x2x60	0	2	20	60
446157	B35 +0x2x100	0	2	30	100
446159	B35 +0x2.5x60	0	2.5	20	60
446163	B35 +0x2.5x100	0	2.5	30	100
446165	B35 +0x3x60	0	3	20	60
446169	B35 +0x3x100	0	3	30	100
487195	1060	0	3.17	-	49

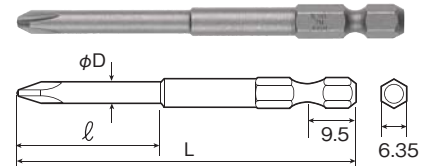

EDP No.	Model No.	PH	φD	L
487200	1061	1	4.76	49
487201	1071	1	4.76	70
487202	1081	1	4.76	89
489672	4301/150	1	4.5	150
487203	1091	1	4.76	152
446424	1062R	2	4.76	49
487205	1062	2	6.35	49
487206	1072	2	6.35	70
487207	1082	2	6.35	89
489255	4302/100	2	6	100
446435	4302/127	2	6	127
489673	4302/150	2	6	150
487208	1092	2	6.35	152
446439	4302/200	2	6	200
487210	1063	3	8	49
487211	1073	3	8	70
487212	1083	3	8	89
489256	4303/100	3	8	100
446437	4303/150	3	8	150

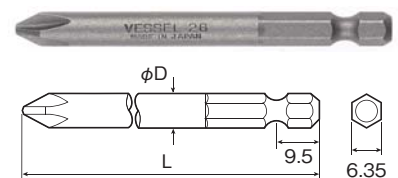

MEGADORA HANDLE

EDP No.	Model No.	Description
122484	900W	MEGADORA Bit Holder, E6.3

Package 60pcs

NEW

6.35mm drive bits can be inserted.



※This BitHolder is subject to change it's features and specs. without notice in prior.

Drive: 1/4" = 6.35mm HEX DRIVE
DIN3126-E6.3



For:

AEG, ARO, ATLAS-COPCO, BIAX, B&D, BOSCH, BUCKEYE-TOOLS, CHICAGO-PNEUMATIC, CLECO, DEPRAG, DESOUTTER, GARDNER-DENVER, HIOS (FERRA TOOLS), HITACHI, INGERSOLL, IWEMA, KELLER, MAKITA, MALL, METABO, NPK, PNEUTEC, ROCKWELL, ROTOR-TOOL, SKIL, STANLEY, THOR, TOHNICHI, URYU, VAN-DORN, VIRAX, WOLF, YOKOTA, YUTANI

POWER BITS

EDP No.	Model No.	PZ	φD	ℓ	L
447304	1060PZ	0	3.17	-	49
447351	1070PZ	0	3.17	-	70
447301	B35 PZ0x2x60	0	2	20	60
447303	B35 PZ0x3x60	0	3	20	60
487215	1061PZ	1	4.76	28	49
487216	1071PZ	1	4.76	49	70
487217	1081PZ	1	4.76	68	89
489257	4301/100PZ	1	4.5	73	100
487218	1091PZ	1	4.76	50	152
487220	1062PZ	2	6.3	28	49
487221	1072PZ	2	6.3	49	70
487222	1082PZ	2	6.3	68	89
489258	4302/100PZ	2	6	73	100
446445	4302/127PZ	2	6	100	127
489674	4302/150PZ	2	6	123	150
487223	1092PZ	2	6.35	50	152
446449	4302/200PZ	2	6	173	200
487225	1063PZ	3	8	20	49
487226	1073PZ	3	8	41	70
487227	1083PZ	3	8	60	89
489234	4304/51PZ	4	8	22	51

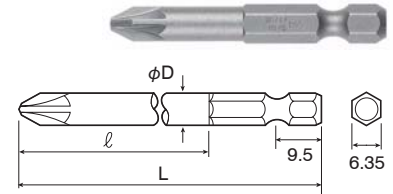

EDP No.	Model No.	w	t	L
489271	5303/51	3	0.5	51
446454	15300	3.4	0.66	70
446459	1560	3.8	0.76	76
489273	5304/51	4	0.6	51
446460	1561	4.75	0.86	76
489276	5355/51	5.5	0.8	51
487240	1523	6.35	0.91	49
446471	157000	3.1	0.56	102
446457	156000	3.1	0.56	76
446450	152000	3.1	0.56	49
446480	1577	9.1	1.27	102
446479	1576	7.9	1.17	102
446478	1575	6.98	1.07	102
446477	1574	6.35	0.96	102
446475	1572	5.46	0.91	102
446474	1571	4.75	0.86	102

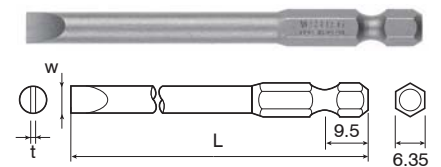

**Drive: 1/4" = 6.35mm HEX DRIVE
DIN3126-E6.3**



For:

AEG, ARO, ATLAS-COPCO, BIAx, B&D, BOSCH, BUCKEY-TOOLS, CHICAGO-PNEUMATIC, CLECO, DEPRAG, DESOUTTER, GARDNER-DENVER, HIOS (FERRA TOOLS), HITACHI, INGERSOLL, IWEMA, KELLER, MAKITA, MALL, METABO, NPK, PNEUTEC, ROCKWELL, ROTOR-TOOL, SKIL, STANLEY, THOR, TOHNICHI, URYU, VAN-DORN, VIRAX, WOLF, YOKOTA, YUTANI

POWER BITS

EPD No.	Model No.	w	t	L
446473	1570	3.8	0.76	102
446472	15700	3.4	0.66	102
446466	1567	9.1	1.27	76
446465	1566	7.9	1.17	76
446464	1565	6.99	1.07	76
446463	1564	6.35	0.97	76
446461	1562	5.46	0.91	76
487260	1527	9.1	1.27	49
487255	1526	7.9	1.17	49
487250	1525	6.99	1.07	49
487245	1524	6.35	0.97	49
487235	1522	5.46	0.91	49
487230	1521	4.75	0.86	49
446452	1520	3.8	0.76	49
446451	15200	3.4	0.66	49

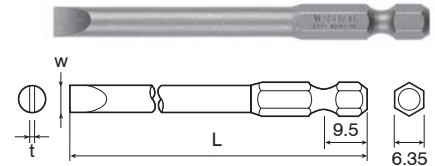

BIT & FINDER SLEEVE

EPD No.	Model No.	w	t	screw head	L
489385	5324/94	5	0.9	4~5	95
487360	6001	5	0.91	5~6	95
487361	6002	6.12	0.97	6~8	95
487362	6003	7	1.07	8~10	95
487363	6004	9	1.17	10~12	95
487364	6005	10	1.27	12~14	98

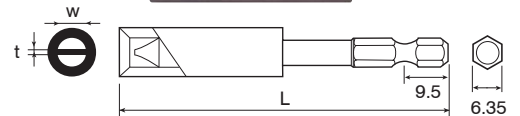

POWER BITS

EPD No.	Model No.	H	φD	L
424080	B35 H2x7x75	H2	7	75
424081	B35 H2x7x100	H2	7	100
424092	B35 H2x7x150H	H2	7	150
447352	21202	H2	3.5	49
424082	B35 H2.5x7x75	H2.5	7	75
424083	B35 H2.5x7x100	H2.5	7	100
424093	B35 H2.5x7x150	H2.5	7	150
487280	21225	H2.5	3.5	49
487281	21203	H3	3.5	49
424084	B35 H3x7x75	H3	7	75
424085	B35 H3x7x100	H3	7	100
424094	B35 H3x7x150	H3	7	150
487282	21204	H4	4.6	49
424086	B35 H4x7x75	H4	7	75
424087	B35 H4x7x100	H4	7	100
424095	B35 H4x7x150	H4	7	150
487283	21205	H5	5.8	49
424088	B35 H5x7x75	H5	7	75
424089	B35 H5x7x100	H5	7	100
424096	B35 H5x7x150	H5	7	150
487284	21206	H6	-	49
424090	B35 H6x7x75	H6	7	75
424091	B35 H6x7x100	H6	7	100
424097	B35 H6x7x150	H6	7	150

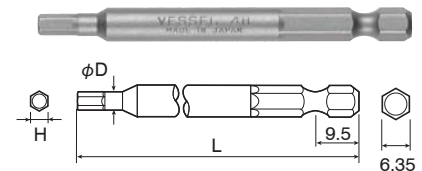

**Drive: 1/4" = 6.35mm HEX DRIVE
DIN3126-E6.3**



For:

AEG, ARO, ATLAS-COPCO, BIAx, B&D, BOSCH, BUCKEY-TOOLS, CHICAGO-PNEUMATIC, CLECO, DEPRAG, DESOUTTER, GARDNER-DENVER, HIOS (FERRA TOOLS), HITACHI, INGERSOLL, IWEMA, KELLER, MAKITA, MALL, METABO, NPK, PNEUTEC, ROCKWELL, ROTOR-TOOL, SKIL, STANLEY, THOR, TOHNICHI, URYU, VAN-DORN, VIRAX, WOLF, YOKOTA, YUTANI

POWER BITS

EDP No.	Model No.	H	φD	L
489296	1337/70	H7	10	70
447306	21208	H8	-	49
489297	1338/70	H8	10	70
424098	B35 H8x10x150H	H8	10	150
489298	1339/70	H9	11	70
447353	21210	H10	-	49
489299	1340/70	H10	12	70
424099	B35 H10x12x150H	H10	12	150
487276	2027	H1/4	-	49

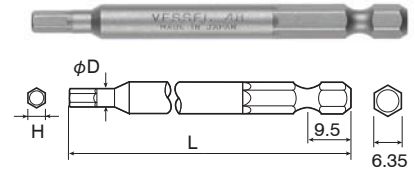

EPD No.	Model No.	T	A	φd	L
446486	T10605	T5	1.37	3.18	49
447355	T10705	T5	1.37	3.18	70
447356	T10805	T5	1.37	3.18	90
446487	T10606	T6	1.65	3.18	49
446498	T10706	T6	1.65	3.18	70
447307	T10806	T6	1.65	3.18	90
447317	T10906	T6	1.65	3.18	152
446488	T10607	T7	1.99	3.18	49
446499	T10707	T7	1.99	3.18	70
446509	T10807	T7	1.99	3.18	90
446519	T10907	T7	1.99	3.18	152
446489	T10608	T8	2.31	3.18	49
446500	T10708	T8	2.31	3.18	70
446510	T10808	T8	2.31	3.18	90
446520	T10908	T8	2.31	3.18	152
446490	T10609	T9	2.5	3.18	49
446501	T10709	T9	2.5	3.18	70
446511	T10809	T9	2.5	3.18	90
446521	T10909	T9	2.5	3.18	152
446491	T10610	T10	2.74	3.96	49
446502	T10710	T10	2.74	3.96	70
446512	T10810	T10	2.74	3.96	90
446522	T10910	T10	2.74	3.96	152
446492	T10615	T15	3.27	3.96	49
446503	T10715	T15	3.27	3.96	70
446513	T10815	T15	3.27	3.96	90
446523	T10915	T15	3.27	3.96	152
446493	T10620	T20	3.86	4.75	49
446504	T10720	T20	3.86	4.75	70
446514	T10820	T20	3.86	4.75	90
446524	T10920	T20	3.86	4.75	152
446494	T10625	T25	4.43	4.75	49
446505	T10725	T25	4.43	4.75	70
446515	T10825	T25	4.43	4.70	90
446525	T10925	T25	4.43	4.75	152
446495	T10627	T27	4.99	6.35	49
446516	T10827	T27	4.99	6.35	90
446526	T10927	T27	4.99	6.35	152

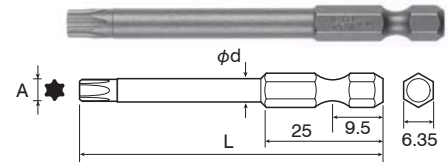

*Production upon your order

Drive: 1/4" = 6.35mm HEX DRIVE
DIN3126-E6.3



For:

AEG, ARO, ATLAS-COPCO, BIAX, B&D, BOSCH, BUCKEYE-TOOLS, CHICAGO-PNEUMATIC, CLECO, DEPRAG, DESOUTTER, GARDNER-DENVER, HIOS (FERRA TOOLS), HITACHI, INGERSOLL, IWEMA, KELLER, MAKITA, MALL, METABO, NPK, PNEUTEC, ROCKWELL, ROTOR-TOOL, SKIL, STANLEY, THOR, TOHNICHI, URYU, VAN-DORN, VIRAX, WOLF, YOKOTA, YUTANI

POWER BITS

EDP No.	Model No.	T	A	φ d	L
446496	T10630	T30	5.52	6.35	49
446507	T10730	T30	5.52	6.35	70
446517	T10830	T30	5.52	6.35	90
446527	T10930	T30	5.52	6.35	152
446497	T10640	T40	6.65	8	49
446508	T10740	T40	6.65	8	70
446518	T10840	T40	6.65	8	90
446528	T10940	T40	6.65	8	152

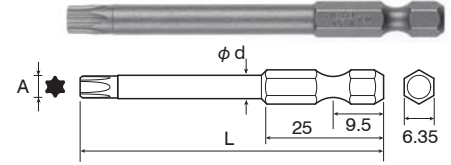

EDP No.	Model No.	T	A	φ d	L
446533	T10610H	T10H	2.74	3.96	49
446544	T10710H	T10H	2.74	3.96	70
446535	T10620H	T20H	3.86	4.75	49
446546	T10720H	T20H	3.86	4.75	70
446556	T10820H	T20H	3.86	4.75	90
446566	T10920H	T20H	3.86	4.75	152

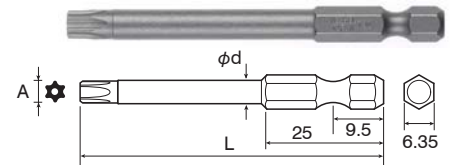

EDP No.	Model No.	IP	A	φ d	L
447209	IP10605	5IP	1.41	3.18	49
447210	IP10705	5IP	1.41	3.18	70
447211	IP10606	6IP	1.64	3.18	49
447212	IP10706	6IP	1.64	3.18	70
447213	IP10806	6IP	1.64	3.18	90
447251	IP10906	6IP	1.64	3.18	152
447215	IP10607	7IP	1.99	3.18	49
447216	IP10707	7IP	1.99	3.18	70
447217	IP10807	7IP	1.99	3.18	90
447252	IP10907	7IP	1.99	3.18	152
447219	IP10608	8IP	2.31	3.18	49
447220	IP10708	8IP	2.31	3.18	70
447221	IP10808	8IP	2.31	3.18	90
447253	IP10908	8IP	2.31	3.18	152
447229	IP10609	9IP	2.5	3.18	49
447236	IP10709	9IP	2.5	3.18	70
447243	IP10809	9IP	2.5	3.18	90
447226	IP10909	9IP	2.5	3.18	152
447227	IP10610	10IP	2.74	3.96	49
447228	IP10710	10IP	2.74	3.96	70
447244	IP10810	10IP	2.74	3.96	90
447254	IP10910	10IP	2.74	3.96	152
447230	IP10615	15IP	3.27	3.96	49
447237	IP10715	15IP	3.27	3.96	70
447245	IP10815	15IP	3.27	3.96	90
447255	IP10915	15IP	3.27	3.96	152
447231	IP10620	20IP	3.86	4.75	49
447238	IP10720	20IP	3.86	4.75	70
447246	IP10820	20IP	3.86	4.75	90
447256	IP10920	20IP	3.86	4.75	152

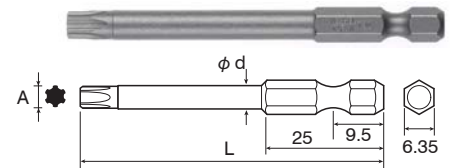

* Production upon your order

**Drive: 1/4" = 6.35mm HEX DRIVE
DIN3126-E6.3**



For:

AEG, ARO, ATLAS-COPCO, BIAX, B&D, BOSCH, BUCKEY-TOOLS, CHICAGO-PNEUMATIC, CLECO, DEPRAG, DESOUTTER, GARDNER-DENVER, HIOS (FERRA TOOLS), HITACHI, INGERSOLL, IWEMA, KELLER, MAKITA, MALL, METABO, NPK, PNEUTEC, ROCKWELL, ROTOR-TOOL, SKIL, STANLEY, THOR, TOHNICHI, URYU, VAN-DORN, VIRAX, WOLF, YOKOTA, YUTANI

POWER BITS

EDP No.	Model No.	IP	A	φ d	L	
447232	IP10625	25IP	4.43	4.75	49	*
447239	IP10725	25IP	4.43	4.75	70	*
447247	IP10825	25IP	4.43	4.75	90	*
447257	IP10925	25IP	4.43	4.75	152	*
447233	IP10627	27IP	4.99	6.35	49	
447240	IP10727	27IP	4.99	6.35	70	*
447248	IP10827	27IP	4.99	6.35	90	*
447258	IP10927	27IP	4.99	6.35	152	*
447234	IP10630	30IP	5.52	6.35	49	*
447241	IP10730	30IP	5.52	6.35	70	*
447249	IP10830	30IP	5.52	6.35	90	*
447259	IP10930	30IP	5.52	6.35	152	
447235	IP10640	40IP	6.65	8	49	*
447242	IP10740	40IP	6.65	8	70	*
447250	IP10840	40IP	6.65	8	90	*
447260	IP10940	40IP	6.65	8	152	

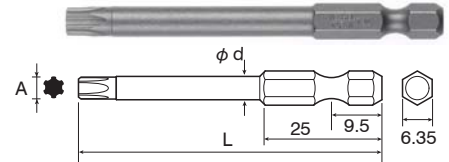

EDP No.	Model No.	SQ	φ d	L	
487301	3041	1 (3/32")	4.76	70	
487306	3042	2 (1/8")	6.35	70	
487308	3062	2 (1/8")	6.35	152	
487311	3043	3 (9/64")	8	70	

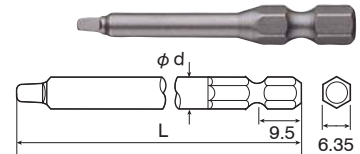

EDP No.	Model No.	H	L	
446577	1732/50	H2	50	
446578	17325/50	H2.5	50	
446579	1733/50	H3	50	
446580	1734/50	H4	50	
446581	1735/50	H5	50	
446582	1736/50	H6	50	
446583	1738/50	H8	50	

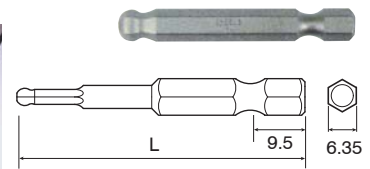

EDP No.	Model No.	TW	L	
424202	B39 TW2x40	TW2	40	
424203	B39 TW3x40	TW3	40	
424204	B39 TW4x40	TW4	40	
424205	B39 TW5x40	TW5	40	

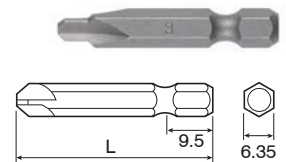

* Production upon your order

**Drive: 1/4" = 6.35mm HEX DRIVE
DIN3126-E6.3**



For:

AEG, ARO, ATLAS-COPCO, BIAX, B&D, BOSCH, BUCKEY-TOOLS, CHICAGO-PNEUMATIC, CLECO, DEPRAG, DESOUTTER, GARDNER-DENVER, HIOS (FERRA TOOLS), HITACHI, INGERSOLL, IWEMA, KELLER, MAKITA, MALL, METABO, NPK, PNEUTEC, ROCKWELL, ROTOR-TOOL, SKIL, STANLEY, THOR, TOHNICHI, URYU, VAN-DORN, VIRAX, WOLF, YOKOTA, YUTANI

MAGNUM BITS

EDP No.	Model No.	PH	L
459613	MX-B35 PH2x50	2	50
459614	MX-B35 PH2x70	2	70
459615	MX-B35 PH2x110	2	110

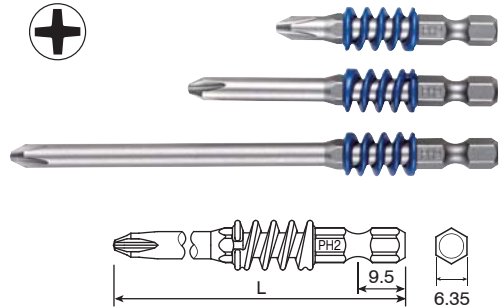

EDP No.	Model No.	PZ	L
459616	MX-B35 PZ2x50	2	50
459617	MX-B35 PZ2x70	2	70
459618	MX-B35 PZ2x110	2	110

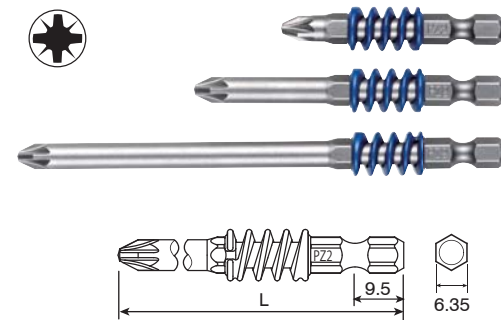

EDP No.	Model No.	T	A	φd	L
459619	MX-B35 TX15x50	T15	3.26	4.5	50
459620	MX-B35 TX15x70	T15	3.26	4.5	70
459621	MX-B35 TX15x110	T15	3.26	4.5	110
459622	MX-B35 TX20x50	T20	3.84	5.0	50
459623	MX-B35 TX20x70	T20	3.84	5.0	70
459624	MX-B35 TX20x110	T20	3.84	5.0	110
459625	MX-B35 TX25x50	T25	4.4	5.0	50
459626	MX-B35 TX25x70	T25	4.4	5.0	70
459627	MX-B35 TX25x110	T25	4.4	5.0	110
459645	MX-B35 TX27x50	T27	4.96	5.5	50
459646	MX-B35 TX27x70	T27	4.96	5.5	70
459647	MX-B35 TX27x110	T27	4.96	5.5	110
459628	MX-B35 TX30x50	T30	5.49	6.0	50
459629	MX-B35 T30x70	T30	5.49	6.0	70
459630	MX-B35 T30x110	T30	5.49	6.0	110

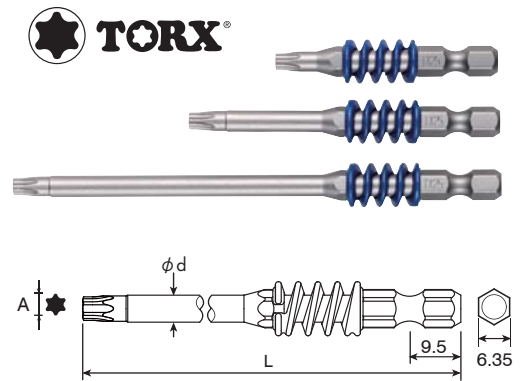

NEW MAGNUM Bit

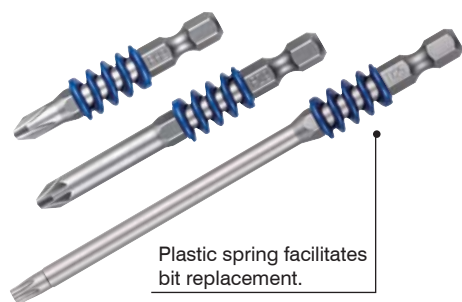

Plastic spring facilitates bit replacement.

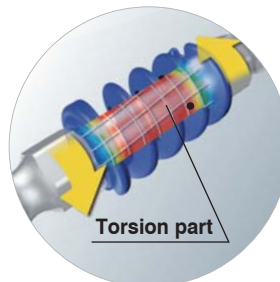

Torsion part reduces impact.



Useful when you remove the bit from the tool.

* Production upon your order

**Drive: 1/4" = 6.35mm HEX DRIVE
DIN3126-E6.3**



For:

AEG, ARO, ATLAS-COPCO, BIAx, B&D, BOSCH, BUCKEYE-TOOLS, CHICAGO-PNEUMATIC, CLECO, DEPRAG, DESOUTTER, GARDNER-DENVER, HIOS (FERRA TOOLS), HITACHI, INGERSOLL, IWEMA, KELLER, MAKITA, MALL, METABO, NPK, PNEUTEC, ROCKWELL, ROTOR-TOOL, SKIL, STANLEY, THOR, TOHNICHI, URYU, VAN-DORN, VIRAX, WOLF, YOKOTA, YUTANI

CUSHION BITS

EDP No.	Model No.	PH	ϕd	Color ring	L
459631	BC35 PH1x50	1	3.0	Yellow	50
459632	BC35 PH1x70	1	3.0	Yellow	70
459633	BC35 PH1x110	1	3.0	Yellow	110
459634	BC35 PH2x50	2	4.5	Red	50
459635	BC35 PH2x70	2	4.5	Red	70
459636	BC35 PH2x110	2	4.5	Red	110

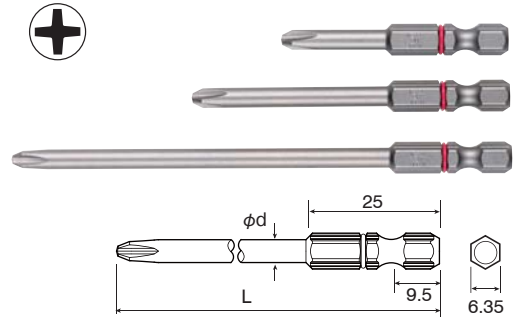

EDP No.	Model No.	PZ	ϕd	Color ring	L
459637	BC35 PZ1x50	1	3.0	Yellow	50
459638	BC35 PZ1x70	1	3.0	Yellow	70
459639	BC35 PZ1x110	1	3.0	Yellow	110
459640	BC35 PZ2x50	2	4.5	Red	50
459641	BC35 PZ2x70	2	4.5	Red	70
459642	BC35 PZ2x110	2	4.5	Red	110

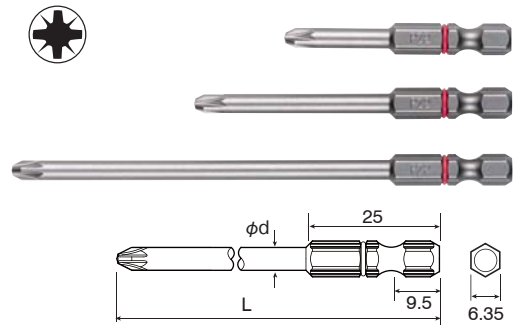

NEW Cushion Bit

By minimizing the gap between chuck and bit, rattling and vibration are reduced.

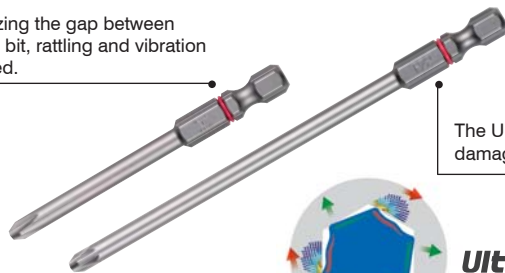

The UltraHex shank does not damage the chuck.





For:
URYU, NPK, FUJI, YOKOTA, YUTANI

DOUBLE END POWER BITS

EPD No.	Model No.	heat treatment	PH	L
425040	B43 +2x75H	H	2	75
425047	B43 +2x100H	H	2	100
425049	B43 +2x150H	H	2	150
425057	B43 +3x100H	H	3	100
446375	B43 +3x150H	H	3	150

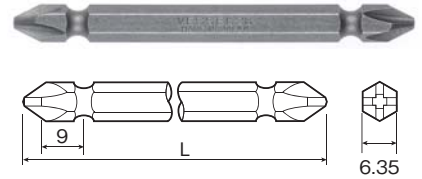

EPD No.	Model No.	heat treatment	PH	L
446669	M-B43 +2x75H	H	2	75
446672	M-B43 +2x100H	H	2	100
446673	M-B43 +2x150H	H	2	150

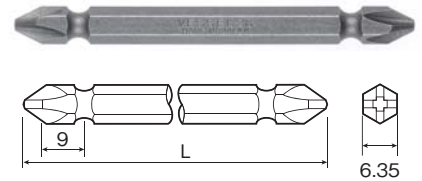

BIT MAG-BOTTLE

EPD No.	Model No.	contents	PH	L
415281	BMG432075H	PH2x75mm ... 20pcs.	2	75
415282	BMG432100H	PH2x100mm ... 20pcs.	2	100

Inner Ctn. 5sets

NEW

Magnetizing bits or demagnetizing as you like.



Endurable PP bottle incorporating a magnetizer in the cap. Contains 20 pieces of bit per bottle

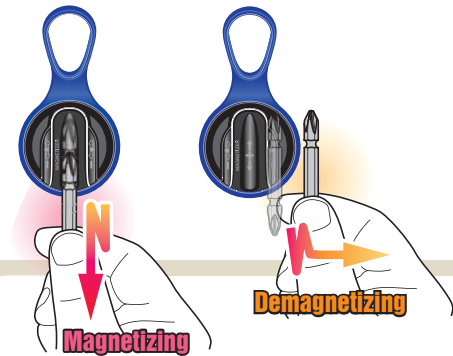
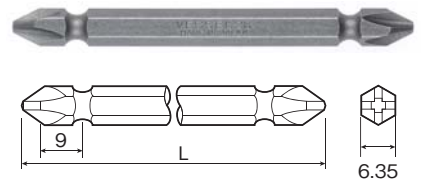

MAGNET-VISCATCHER

EPD No.	Model No.	contents	φ D	PH	L
486575	NMC-2P	2pcs.	16.9	2	27

NEW

Strong magnet catches screws.



φ D = 16.9



The following bits can be inserted.

- Bit can be inserted until:
- 6.35mm Hex Drive
- 6.4mm φ

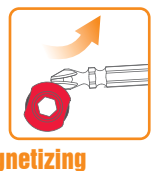
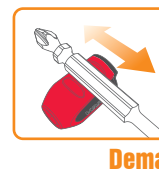
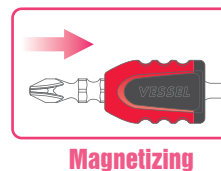



For:

VESSEL, HITACHI, MAKITA, NPK, YOKOTA, YUTANI, FUJI, RYOBI, TOHNICHI, PANASONIC, MAX

DOUBLE END POWER BITS

EPD No.	Model No.	heat treatment	PH	L
413040	A14 +2x45G	G	2	45
413041	A14 +2x45H	H	2	45
413042	A14 +2x65H	H	2	65
413255	A14 +2x300G	G	2	300

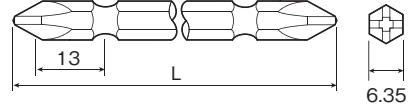

EPD No.	Model No.	heat treatment	PH	L
413408	M-A14 +2x150H	H	2	150

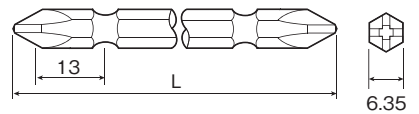

EPD No.	Model No.	heat treatment	PH	L
413355	A14H +2x110H	H	2	110



EPD No.	Model No.	heat treatment	PH	L
415331	A14P +2x65H	H	2	65

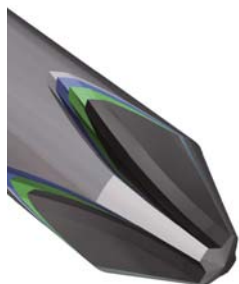
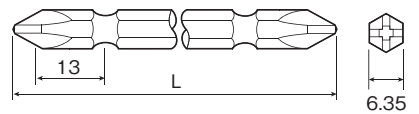

Bit selection

● Selecting Phillips tip suitable for screw head hole

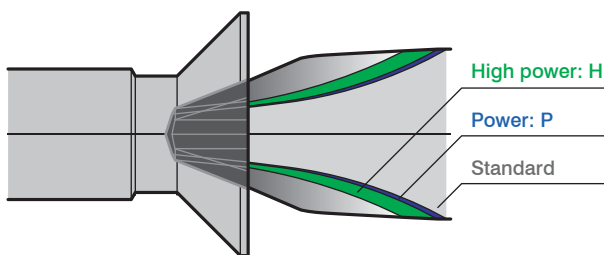

A14 M-A14 Standard	A14P Power	A14H High power
4.2~5.5 mm	3.2~4.2 mm	2.7~3.2 mm

* M dimension: the size of a cross recess on a screw head viewed from directly above

**Drive: 1/4" = 6.35mm HEX DRIVE
DIN3126-E6.3**



For:

AEG, ARO, ATLAS-COPCO, BIAX, B&D, BOSCH, BUCKEY-TOOLS, CHICAGO-PNEUMATIC, CLECO, DEPRAG, DESOUTTER, GARDNER-DENVER, HIOS (FERRA TOOLS), HITACHI, INGERSOLL, IWEMA, KELLER, MAKITA, MALL, METABO, NPK, PNEUTEC, ROCKWELL, ROTOR-TOOL, SKIL, STANLEY, THOR, URYU, VAN-DORN, VIRAX, WOLF, YOKOTA, YUTANI

PH/PZ-PLAIN SLOTTED BITS FOR TERMINAL SCREWS

EPD No.	Model No.	PH	φ d	L
459610	PHS1110	1	4.7	110
459611	PHS2110	2	6.2	110

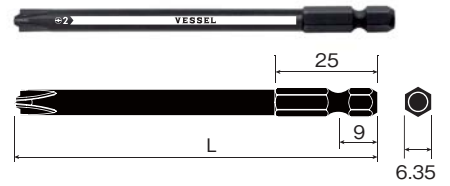

EPD No.	Model No.	PZ	φ d	L
459612	PZS2110	2	6.2	110

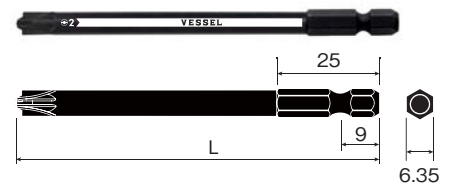

NEW



For Phillips/Pozidriv-slotted screws that are widely used. For fastening terminal screws on distribution board, fitting hardware to hold electric wire, plumbing, and air conditioner installation.

**Drive: 1/4" = 6.35mm HEX DRIVE
DIN3126-E6.3**



For:

AEG, ARO, ATLAS-COPCO, BIAx, B&D, BOSCH, BUCKEY-TOOLS, CHICAGO-PNEUMATIC, CLECO, DEPRAG, DESOUTTER, GARDNER-DENVER, HIOS (FERRA TOOLS), HITACHI, INGERSOLL, IWEMA, KELLER, MAKITA, MALL, METABO, NPK, PNEUTEC, ROCKWELL, ROTOR-TOOL, SKIL, STANLEY, THOR, TOHNICHI, URYU, VAN-DORN, VIRAX, WOLF, YOKOTA, YUTANI

SOCKET BITS, Nut Setters

EDP No.	Model No.	A/F	φD	l ₁	l ₂	L
489301	1304/50	4	8	3	15	50
489314	1304/75	4	8	3	25	75
489327	1304/100	4	8	3	25	100
489302	1345/50	4.5	8	3	15	50
489315	1345/75	4,5	8	3	25	75
489328	1345/100	4.5	8	3	25	100
489303	1305/50	5	8.5	3.5	15	50
489316	1305/75	5	8.5	3.5	25	75
489329	1305/100	5	8.5	3.5	25	100
446602	1305/150	5	8.5	3.5	25	150
489304	1355/50	5.5	9	3.5	15	50
489317	1355/75	5.5	9	3.5	25	75
489330	1355/100	5.5	9	3.5	25	100
446603	1355/150	5.5	9	3.5	25	150
489305	1306/50	6	10	4	15	50
489318	1306/75	6	10	4	25	75
489331	1306/100	6	10	4	25	100
446604	1306/150	6	10	4	25	150
489306	1307/50	7	13	5	15	50
489319	1307/75	7	13	5	25	75
489332	1307/100	7	13	5	25	100
446605	1307/150	7	13	5	25	150
489307	1308/50	8	13	5	15	50
489320	1308/75	8	13	5	30	75
489333	1308/100	8	13	5	30	100
446606	1308/150	8	13	5	30	150
489308	1309/50	9	14	5.5	15	50
489321	1309/75	9	14	5.5	30	75
489334	1309/100	9	14	5.5	30	100
489309	1310/50	10	16	6.5	15	50
489322	1310/75	10	16	6.5	30	75
489335	1310/100	10	16	6.5	30	100
446607	1310/150	10	16	6.5	30	150
489310	1311/50	11	17	7	15	50
489323	1311/75	11	17	7	30	75
489336	1311/100	11	17	7	30	100
489311	1312/50	12	19	7.5	15	50
489324	1312/75	12	18	7.5	30	75
489337	1312/100	12	18	7.5	30	100
446608	1312/150	12	18	7.5	30	150
489312	1313/50	13	19	8	15	50
489325	1313/75	13	19	8	30	75
489338	1313/100	13	19	8	30	100
446609	1313/150	13	19	8	30	150
489313	1314/50	14	20	8	15	50
489326	1314/75	14	20	8	30	75
489339	1314/100	14	20	8	30	100

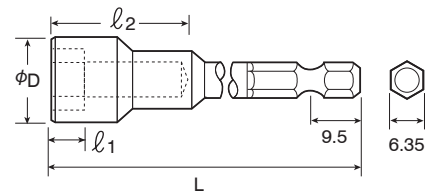

* Production upon your order

Drive: 1/4"=6.35mm HEX DRIVE
DIN3126-E6.3



For:

AEG, ARO, ATLAS-COPCO, BIAH, B&D, BOSCH, BUCKEY-TOOLS, CHICAGO-PNEUMATIC, CLECO, DEPRAG, DESOUTTER, GARDNER-DENVER, HIOS (FERRA TOOLS), HITACHI, INGERSOLL, IWEMA, KELLER, MAKITA, MALL, METABO, NPK, PNEUTEC, ROCKWELL, ROTOR-TOOL, SKIL, STANLEY, THOR, TOHNICHI, URYU, VAN-DORN, VIRAX, WOLF, YOKOTA, YUTANI

SOCKET BITS, Nut Setters

EDP No.	Model No.	A/F	φD	ℓ1	L
489340	1305/50M	5	8.5	3.5	50
489351	1305/75M	5	8.5	3.5	75
489362	1305/100M	5	8.5	3.5	100
446619	1305/150M	5	8.5	3.5	150
489341	1355/50M	5.5	9	3.5	50
489352	1355/75M	5.5	9	3.5	75
489363	1355/100M	5.5	9	3.5	100
446620	1355/150M	5.5	9	3.5	150
489342	1306/50M	6	10	4	50
489353	1306/75M	6	10	4	75
489364	1306/100M	6	10	4	100
446621	1306/150M	6	10	4	150
489343	1307/50M	7	13	4.5	50
489354	1307/75M	7	13	4.5	75
489365	1307/100M	7	13	4.5	100
446622	1307/150M	7	13	5	150
489344	1308/50M	8	13	5	50
489355	1308/75M	8	13	5	75
489366	1308/100M	8	13	5	100
446623	1308/150M	8	13	5	150
489345	1309/50M	9	14	5.5	50
489356	1309/75M	9	14	5.5	75
489367	1309/100M	9	14	5.5	100
489346	1310/50M	10	16	6.5	50
489357	1310/75M	10	16	6.5	75
489368	1310/100M	10	16	6.5	100
446624	1310/150M	10	16	6.5	150
489347	1311/50M	11	17	7	50
489358	1311/75M	11	17	7	75
489369	1311/100M	11	17	7	100
489348	1312/50M	12	19	7.5	50
489359	1312/75M	12	18	7.5	75
489370	1312/100M	12	18	7.5	100
446625	1312/150M	12	18	7.5	150
489349	1313/50M	13	19	8	50
489360	1313/75M	13	19	8	75
489371	1313/100M	13	19	8	100
446626	1313/150M	13	19	8	150
489350	1314/50M	14	20	8	50
489361	1314/75M	14	20	8	75
489372	1314/100M	14	20	8	100



MAGNETIC

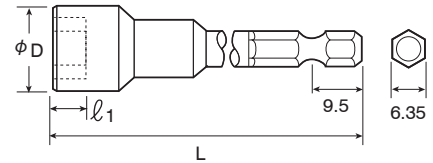

* Production upon your order

Drive: 5/16" = 8mm HEX DRIVE



For: BUCKEYE-TOOLS, DEMAG(FMA), DESOUTTER, FIAM, GRASSO, RUPES, SUHNER

POWER BITS

EDP No.	Model No.	PH	ϕD	l	L
447319	4401/32	1	4.5	16	32
489391	4401/50	1	4.5	34	50
489392	4402/50	2	6	34	50

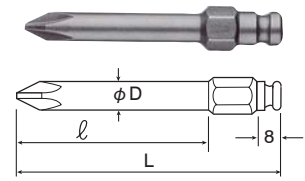

EDP No.	Model No.	PZ	ϕD	l	L
447354	4402/92PZ	2	6	76	92

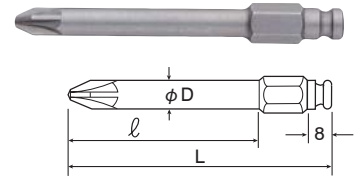

EDP No.	Model No.	w	t	l	L
446585	5403/76	3	0.5	60	76
489431	5403/51	3	0.5	35	51

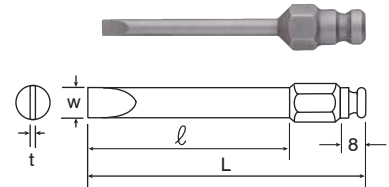

EDP No.	Model No.	H	ϕD	l	L
447321	1433/50	H3	6	34	50
447322	1434/50	H4	6	34	50
447323	1435/50	H5	8	—	50
447324	1436/50	H6	8	—	50
447325	1438/50	H8	8	—	50

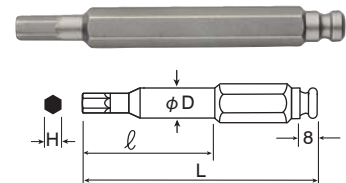

**Drive: 7/16" = 11mm HEX DRIVE
DIN3126-E11.2**



For: AEG, ARO, ATLAS-COPCO, B&D, BOSCH, BUCKEYE-TOOLS, CHICAGO-PNEUMATIC, CINCINNATI-ELECTRIC, CLARK, DEMAG(FMA), FEIN, HOLZ-HER, INGASOLL, KELLER, MILWAUKEE-ELECTRIC

EDP No.	Model No.	H	L
489594	1535/70	H5	70
489595	1536/70	H6	70
489597	1538/70	H8	70
489599	1540/70	H10	70

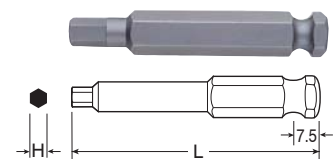

* Production upon your order

Drive: 1/4"=6.35mm HEX DRIVE
DIN3126-E6.3



For:

AEG, ARO, ATLAS-COPCO, BIAx, B&D, BOSCH, BUCKEYE-TOOLS, CHICAGO-PNEUMATIC, CLECO, DEPRAG, DESOUTTER, GARDNER-DENVER, HIOS (FERRA TOOLS), HITACHI, INGERSOLL, IWEMA, KELLER, MAKITA, MALL, METABO, NPK, PNEUTEC, ROCKWELL, ROTOR-TOOL, SKIL, STANLEY, THOR, TOHNICHI, URYU, VAN-DORN, VIRAX, WOLF, YOKOTA, YUTANI

ADAPTERS

EDP No.	Model No.	SQ	L
487380	X5001	6.35 (1/4")	35
487381	X5002	6.35 (1/4")	51
487382	X5003	6.35 (1/4")	76
487383	X5004	6.35 (1/4")	102
487384	X5005	6.35 (1/4")	152
487390	X5011	9.52 (3/8")	41.27
487391	X5012	9.52 (3/8")	51
487392	X5013	9.52 (3/8") </td <td>76</td>	76
487393	X5014	9.52 (3/8")	102
487394	X5015	9.52 (3/8")	152

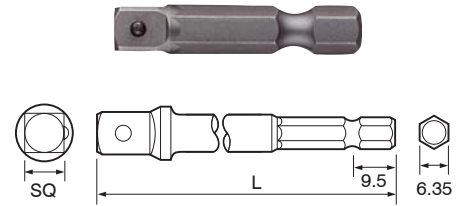

Drive: SCREW SHANK DRIVER BITS



AEG, ARO, ATLAS-COPCO, BIAx, B&D, BOSCH, BUCKEYE-TOOLS, CHICAGO-PNEUMATIC, CLECO, DERAG, DESOUTTER, GARDNER-DENVER, HIOS (FERRA TOOLS), HITACHI, INGERSOLL, IWEMA, KELLER, MAKITA, MALL, METABO, NPK, PNEUTEC, ROCKWELL, ROTOR-TOOL, SKIL, STANLEY, THOR, TOHNICHI, URYU, VAN-DORN, VIRAX, WOLF, YOKOTA, YUTANI

SCREW SHANK DRIVER BITS

EDP No.	Model No.	PH	M	φd	ℓ	L
489656	3491/34	1	M4xP0.7	6	26	34
489657	3492/34	2	M4xP0.7	6	26	34
489663	3592/34	2	M5xP0.8	6	24	34

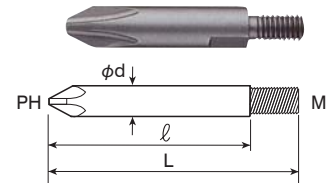

EDP No.	Mode No.	PZ	M	φd	ℓ	L
489658	3491/34PZ	1	M4xP0.7	6	26	34
489659	3492/34PZ	2	M4xP0.7	6	26	34
489665	3592/34PZ	2	M5xP0.8	6	24	34

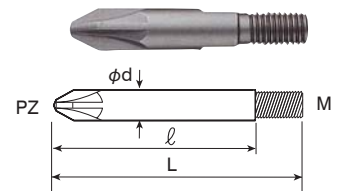

Drive: 5/16"=8mm HEX DRIVE



For: BUCKEYE-TOOLS, DEMAG (FMA), DESOUTTER, FIAM, GRASSO, RUPES, SUHNER

BIT HOLDERS

EDP No.	Model No.	A/F	φD	ℓ ₁	L
489209	3416M/70	8	12.7	12.5	70

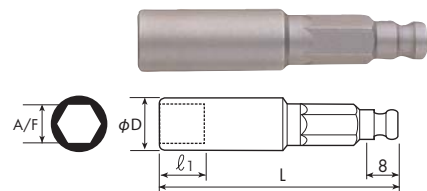

EDP No.	Model No.	A/F	φD	ℓ ₁	L
489207	3414M/54	6.35	11.1	10.5	54
489206	3414/50	6.35	11.1	10	50

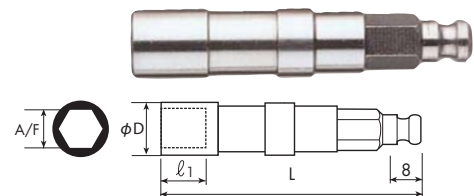

* Production upon your order

**Drive: 1/4" = 6.35mm HEX DRIVE
DIN3126-E6.3**



**BIT HOLDERS WITH
MG.VISCATCH**

For:

AEG, ARO, ATLAS-COPCO, BIAX, B&D, BOSCH, BUCKEYE-TOOLS, CHICAGO-PNEUMATIC, CLECO, DEPRAG, DESOUTTER, GARDNER-DENVER, HIOS (FERRA TOOLS), HITACHI, INGERSOLL, IWEMA, KELLER, MAKITA, MALL, METABO, NPK, PNEUTEC, ROCKWELL, ROTOR-TOOL, SKIL, STANLEY, THOR, TOHNICHI, URYU, VAN-DORN, VIRAX, WOLF, YOKOTA, YUTANI

EDP No.	Model No.	ϕD	L
486345	MBC	17	71

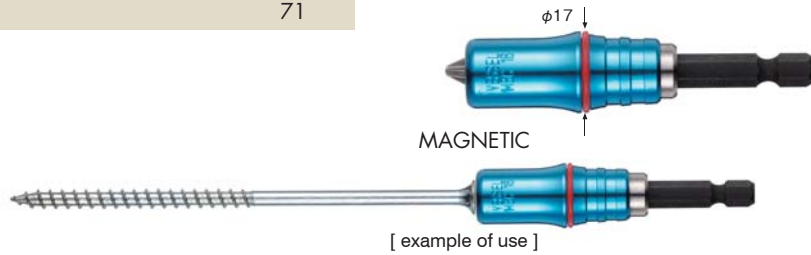

EDP No.	Model No.	ϕD	A/F	l_1	L
482433	DBHM-01	11.1	6.35	9.5	60
489199	3314M/75	11.1	6.35	10	75
447320	3314M/150	11.1	6.35	10	150
487371	BH44M	11.1	6.35	10	102
487372	BH46M	11.1	6.35	10	152



EDP No.	Model No.	ϕD	A/F	l_1	L
482431	DBH-01	11.1	6.35	9.5	60
487366	BH44	11.1	6.35	10	102
487367	BH46	11.1	6.35	10	152



EDP No.	Model No.	ϕD	l_1	L
482434	DBHM-02 MAGNETIC	14.4	9	62
482432	DBH-02 NON MAGNETIC	14.4	9	62



TORSION BIT HOLDER

EDP No.	Model No.	ϕd	ϕD	l_1	L
459643	EU-BH-14	3.5	12.5	10	65
459644	EU-BH-14H	3.8	12.5	10	65

Bit holder with a torsion part

Torsion shank absorbs impact.
Prevents screw stripping and bit breakage.
Designed for PH2/PZ2 DIN3126-C6.3 Bits

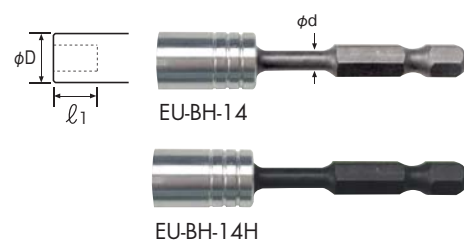

MEGADORA HANDLE

EDP No.	Model No.	Description
122484	900W	MEGADORA Bit Holder, E6.3

Package 60pcs

NEW

6.35mm drive bits can be inserted.



※ This BitHolder is subject to change its features and specs. without notice in prior.

**Drive: 1/4"=6.35mm HEX DRIVE
DIN3126-E6.3**



For:

AEG, ARO, ATLAS-COPCO, BIA, B&D, BOSCH, BUCKEY-TOOLS, CHICAGO-PNEUMATIC, CLECO, DEPRAG, DESOUTTER, GARDNER-DENVER, HIOS(FERRA TOOLS), HITACHI, INGERSOLL, IWEMA, KELLER, MAKITA, MALL, METABO, NPK, PNEUTEC, ROCKWELL, ROTOR-TOOL, SKIL, STANLEY, THOR, TOHNICHI, URYU, VAN-DORN, VIRAX, WOLF, YOKOTA, YUTANI

MG.VISCATCH BIT

EDP No.	Model No.	Tip Size	φD	L
447111	MMBC JT10×49	T10	12	49
447112	MMBC JT10×70	T10	12	70
447115	MMBC JT15×49	T15	12	49
447116	MMBC JT15×70	T15	12	70
447113	MMBC JT20×49	T20	12	49
447101	MMBC T20×75	T20	12	75
447109	MMBC T20×150	T20	12	150
447117	MMBC JT25×49	T25	12	49
447118	MMBC JT25×70	T25	12	70
459601	MMBC PH2×49	PH2	12	49
459602	MMBC PH2×70	PH2	12	70
459603	MMBC PZ2×49	PZ2	12	49
459604	MMBC PZ2×70	PZ2	12	70



**Drive: 1/4"=6.35mm HEX SHANK
DIN3126-C6.3**



EDP No.	Model No.	Tip Size	φD	L
447104	MMBC T10×33	T10	12	33
447102	MMBC T15×33	T15	12	33
447103	MMBC T20×33	T20	12	33
447110	MMBC T25×33	T25	12	33
447105	MMBC PH1×33	PH1	12	33
447106	MMBC PH2×33	PH2	12	33
447107	MMBC PZ1×33	PZ1	12	33
447108	MMBC PZ2×33	PZ2	12	33

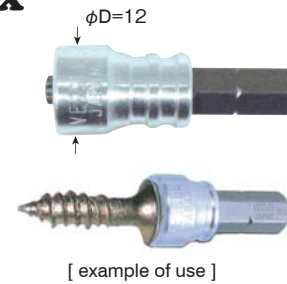

EDP No.	Model No.	φd	L
447329	T10 x 33 bit only, for MMBC	3.02	33
447330	T15 x 33 bit only, for MMBC	3.56	33
447331	T20 x 33 bit only, for MMBC	4.5	33
447332	T25 x 33 bit only, for MMBC	4.55	33
447333	PH1 x 33 bit only, for MMBC	4.5	33
447334	PH2 x 33 bit only, for MMBC	4.5	33
447335	PZ1 x 33 bit only, for MMBC	4.5	33
447336	PZ2 x 33 bit only, for MMBC	4.5	33
447337	T10 x 49 bit only, for MMBC	3.02	49
447338	T10 x 70 bit only, for MMBC	3.02	70
447361	T15 x 49 bit only, for MMBC	3.56	49
447362	T15 x 70 bit only, for MMBC	3.56	70
447339	T20 x 49 bit only, for MMBC	4.5	49
447340	T20 x 75 bit only, for MMBC	4.5	75
447341	T20 x 150 bit only, for MMBC	4.5	150
447363	T25 x 49 bit only, for MMBC	4.55	49
447364	T25 x 70 bit only, for MMBC	4.55	70
459605	PH2 x 49 bit only, for MMBC	4.5	49
459606	PH2 x 70 bit only, for MMBC	4.5	70
459607	PZ2 x 49 bit only, for MMBC	4.5	49
459608	PZ2 x 70 bit only, for MMBC	4.5	70



* Production upon your order

Since 1916, **VESSEL** has been a Japanese leading manufacturing company of screwdrivers and bits.



1916

VESSEL factory founded
Hand screwdrivers production started

1933

VESSEL trademark registered

1954

Industrial bits production started



1961

Invented double-ended bits first in the world
and started the production and sales



1970

Enhanced the product line of industrial bits for
professional use in the production and/or the assembly lines
during Japan's Rapid Economic Growth



2000

Launched problem-solving bits
such as Torsion Bits and sockets

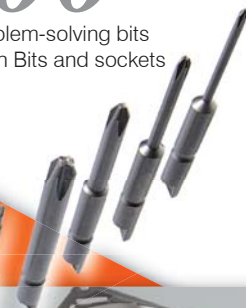

2016 **100th**
VESSEL 1916-2016

Enhanced the product line of precision bits for the screw
tightening in the small electronic devices and/or the precision instrument industries

INQUIRY SHEET Please fill out this sheet for made-to-order bits.

Part No. _____ Date: _____

Similar VESSEL item _____ Ref.No.: _____

TIP

CROSS POINT (00, 0, 1, 2, 3)	TORX [®] (1-10,15, 20, 25, 27, 30, 40)	HEXAGON HEAD (1.5, 2, 2.5, 3, 4, 5, 6, 8, 9, 10, 1/4"=6.35)	TRI WING 3-W (1, 2, 3, 4, 5)
PoziDRIV [®] (0, 1, 2, 3, 4)	TORX [®] (TAMPER PROOF) (8-10,15, 20, 25, 27, 30, 40)	BALL POINT (2, 2.5, 3, 4, 5, 6, 8)	HEX SOCKET 6P (2.3-14mm) Sleeve thickness: 1mm or more
PLAIN SLOT (METRIC)	TORX ^{Plus} (2-10,15, 20, 25, 27, 30, 40)	SQUARE HEAD (1, 2, 3, 4, 5)	OTHERS
PLAIN SLOT FINDER SLEEVE (METRIC)			

DRIVE

<input type="checkbox"/> 1/4"=6.35mm HEX DRIVE	<input type="checkbox"/> φ 4mm SHANK DRIVE	<input type="checkbox"/> 1/4"=6.35mm HEX DRIVE
<input type="checkbox"/> 3mm HEX DRIVE	<input type="checkbox"/> φ 5mm SHANK DRIVE	<input type="checkbox"/> 5/16"=8mm HEX DRIVE
<input type="checkbox"/> 5/16"=8mm HEX DRIVE	<input type="checkbox"/> φ 4mm SHANK DRIVE	<input type="checkbox"/> DOUBLE ENDED
<input type="checkbox"/> 7/16"=11mm HEX DRIVE	<input type="checkbox"/> SCREW SHANK	<input type="checkbox"/> OTHERS

DIMENSIONS

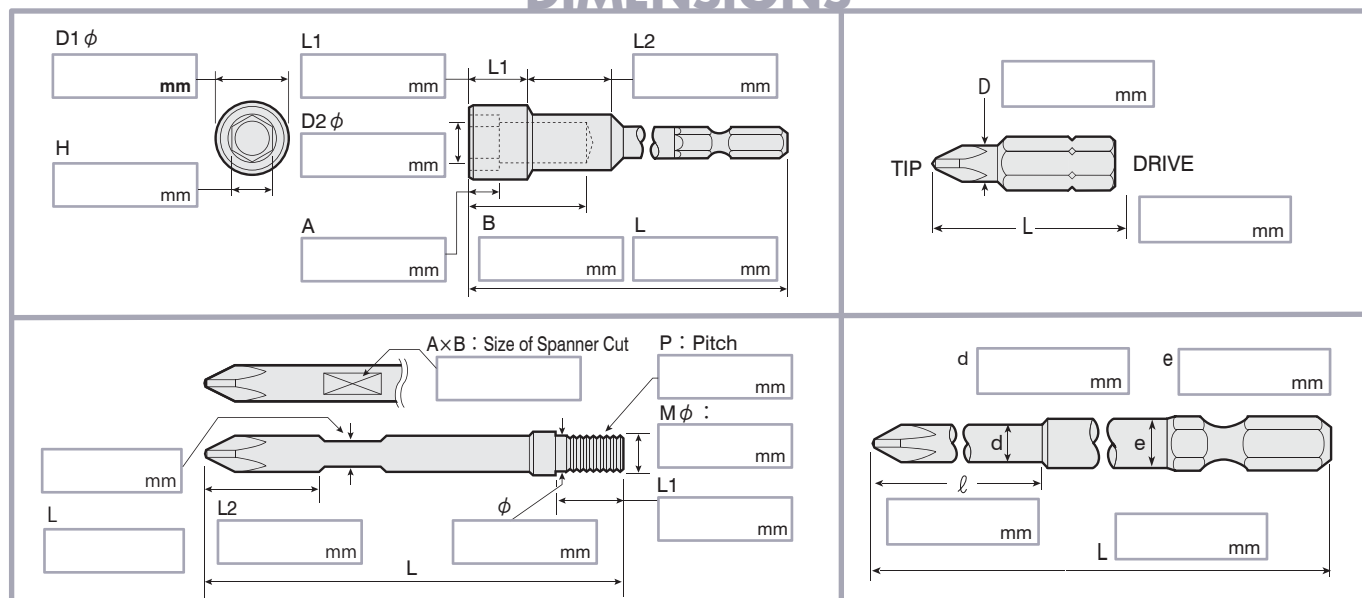

OTHERS

SAMPLE SCREW	<input type="checkbox"/> YES(pcs) <input type="checkbox"/> NO	SAMPLE BIT	<input type="checkbox"/> YES(pcs) <input type="checkbox"/> NO
TOLERANCE	<input type="checkbox"/> VESSEL Spec. <input type="checkbox"/> Specified()	QUANTITY	pcs (Min. 10pcs)
SURFACE TREATMENT	<input type="checkbox"/> Shot Blast <input type="checkbox"/> Black Finish		
MAGNETIC / MAGNETIZED	<input type="checkbox"/> Yes ※For Nut Setters inquiry, the bolt with flange <input type="checkbox"/> No <input type="checkbox"/> Yes (Sample bolt needed) <input type="checkbox"/> No		
HARDNESS	<input type="checkbox"/> HRC 62±1 <input type="checkbox"/> HRC 60±1 <input type="checkbox"/> HRC 57±1 <input type="checkbox"/> OTHERS() <input type="checkbox"/> Nut Setters (VESSEL Spec.)		